

## JAL-KC7-HQ08B

OmniVision OV8825 MIPI Schnittstelle Autofokus 8MP Kameramodul



<b>Kameramodul Nr.</b>	<b>JAL-KC7-HQ08B</b>
<b>Bildsensor</b>	OV8825
<b>EFL</b>	4.39 mm
<b>F.NO</b>	2.8
<b>Pixel</b>	3264 x 2448
<b>Blickwinkel</b>	69.5°
<b>Linsentyp</b>	1/4 Zoll
<b>Objektivabmessungen</b>	8.6 x 8.6 x 5.38 mm
<b>Modulgröße</b>	14.5 x 8.6 mm
<b>Modultyp</b>	Autofokus
<b>Schnittstelle</b>	MIPI

<b>Gegenstecker Teile-Nr. QG2330421Y-M08-7H</b>	
	
Gegenstecker auf der Hauptplatine. Separat erhältlich.	

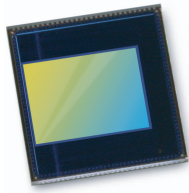

# OV8825 8-megapixel product brief



## High Performance 8-Megapixel Camera With Advanced OmniBSI+ Pixel Architecture for Superior Image Quality With Low-Cost Structure



available in a lead-free package

The 1/3.2-inch OV8825 is an 8-megapixel CameraChip™ sensor built on OmniVision's advanced OmniBSI+™ pixel architecture, providing many significant improvements over the previous OmniBSI™ generation, including a 60 percent increase in full-well capacity, a 10 percent increase in quantum efficiency and a 10 percent improvement in low-light sensitivity. OmniBSI+ pixel architecture enables the OV8825 to dramatically improve image and video capture in both bright and low-light conditions, making it a highly attractive solution for next generation for smartphones and tablets.

The OV8825 operates at 24 frames per second (fps) in full resolution, and in 1080p high-definition (HD) video mode at 30 fps or 720p at 60 fps. The sensor's high frame rate also helps eliminate image lag for shutter-less designs, and enables continuous shooting, minimized rolling shutter effect and real-time image capture with no lag between resolutions. A high-speed, 4-lane MIPI interface facilitates the required high data transfer rates necessary for capturing 10-bit 8-megapixel images and HD video.

An integrated scaler offers electronic image stabilization and enables it to maintain full field-of-view (FOV) with improved signal-to-noise performance in 1080p high-definition (HD) video mode at 30 fps. The sensor's 2 x 2 binning functionality with a post-binning re-sampling filter function minimizes spatial artifacts and removes image artifacts around edges, delivering clean, crisp color images.

The OV8825 fits into the industry standard 8.5 x 8.5 mm module size and features certain image processing functions such as lens shading correction and defect pixel correction, as well as 256-bytes of embedded one-time programmable memory.

Find out more at [www.ovt.com](http://www.ovt.com).

## Applications

- Mobile Phones
- Digital Video Camcorders (DVC)
- Digital Still Cameras (DSC)

## Product Features

- OmniBSI+™ technology
- automatic black level calibration (ABLC)
- programmable controls for frame rate, mirror and flip, cropping, windowing, and scaling
- image quality controls: lens correction and defective pixel canceling
- support for output formats: 10-bit RAW RGB (MIPI)
- support for horizontal and vertical subsampling
- support for images sizes: 8 Mpixel, EIS1080p, 1080p, EIS720p, EISQ 1080p, Q1080p, EISVGA, VGA, QVGA, etc.
- support 2x2 binning
- standard serial SCCB interface
- MIPI serial output interface
- 256 bytes embedded one-time programmable (OTP) memory for part identification, etc.
- on-chip phase lock loop (PLL)
- programmable I/O drive capability
- built-in 1.5V regulator for core

# OV8825

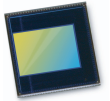

## Ordering Information

- OV08825-G04A  
(color, chip probing, 200 μm backgrinding, reconstructed wafer)

## Product Specifications

- active array size: 3296 x 2460
- max S/N ratio: 35.7 dB
- power supply:
  - core: 1.5 VDC ±5% (internal regulator optional)
  - analog: 2.6 - 3.0V
  - I/O: 1.7 - 3.0V
- power requirements:
  - active: 160 mA (358 mW)
  - standby: 30 μA
- temperature range:
  - operating: -30°C to 70°C junction temperature
  - stable image: 0°C to 50°C junction temperature
- output formats: 10-bit RGB RAW
- lens size: 1/3.2"
- lens chief ray angle: 27° non-linear
- input clock frequency: 6 - 27 MHz
- dynamic range: 70.45 dB @ 8x gain
- maximum image transfer rate:
  - 8MP: 24 fps
  - EIS1080p: 30 fps
  - EIS720p: 60 fps
- sensitivity: 725 mV/lux-sec
- scan mode: progressive
- maximum exposure interval: 2480 x t<sub>row</sub>
- pixel size: 1.4 μm x 1.4 μm
- dark current: 8 mV/s @ 50°C junction temperature
- image area: 4614 μm x 3444 μm
- die dimensions: 6350 μm x 6750 μm

## Functional Block Diagram

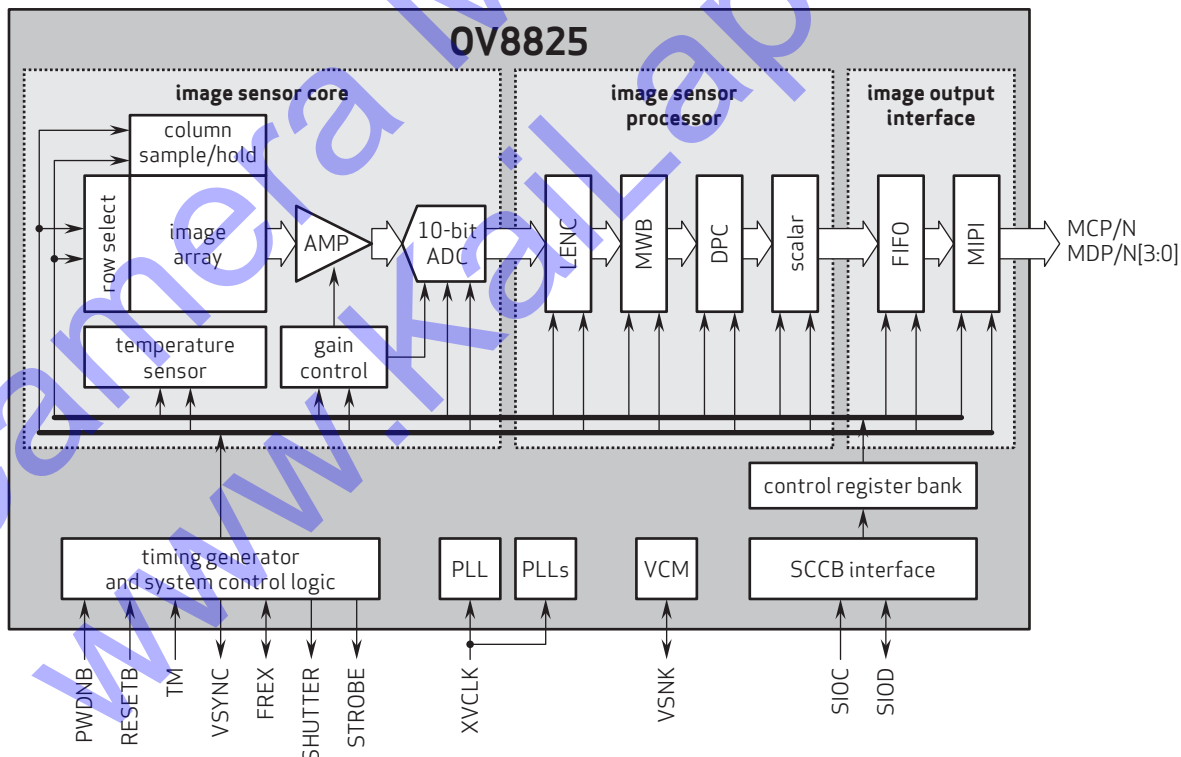

4275 Burton Drive  
Santa Clara, CA 95054  
USA

Tel: +1 408 567 3000  
Fax: +1 408 567 3001  
www.ovt.com

OmniVision reserves the right to make changes to their products or to discontinue any product or service without further notice. OmniVision, the OmniVision logo and OmniPixel are registered trademarks of OmniVision Technologies, Inc. OmniBSI-2 is a trademark of OmniVision Technologies, Inc. All other trademarks are the property of their respective owners.

OmniVision